

Charterhouse stacking pews - lookbook

Some architectural settings (May 2026)



v

© Luke Hughes Designs 2026



*** 10 year warranty**

Introduction	3
Site photos and detailed images	4-53
Handling and storage	61 - 62
Line drawings	63 - 64
Select client list (worship)	67



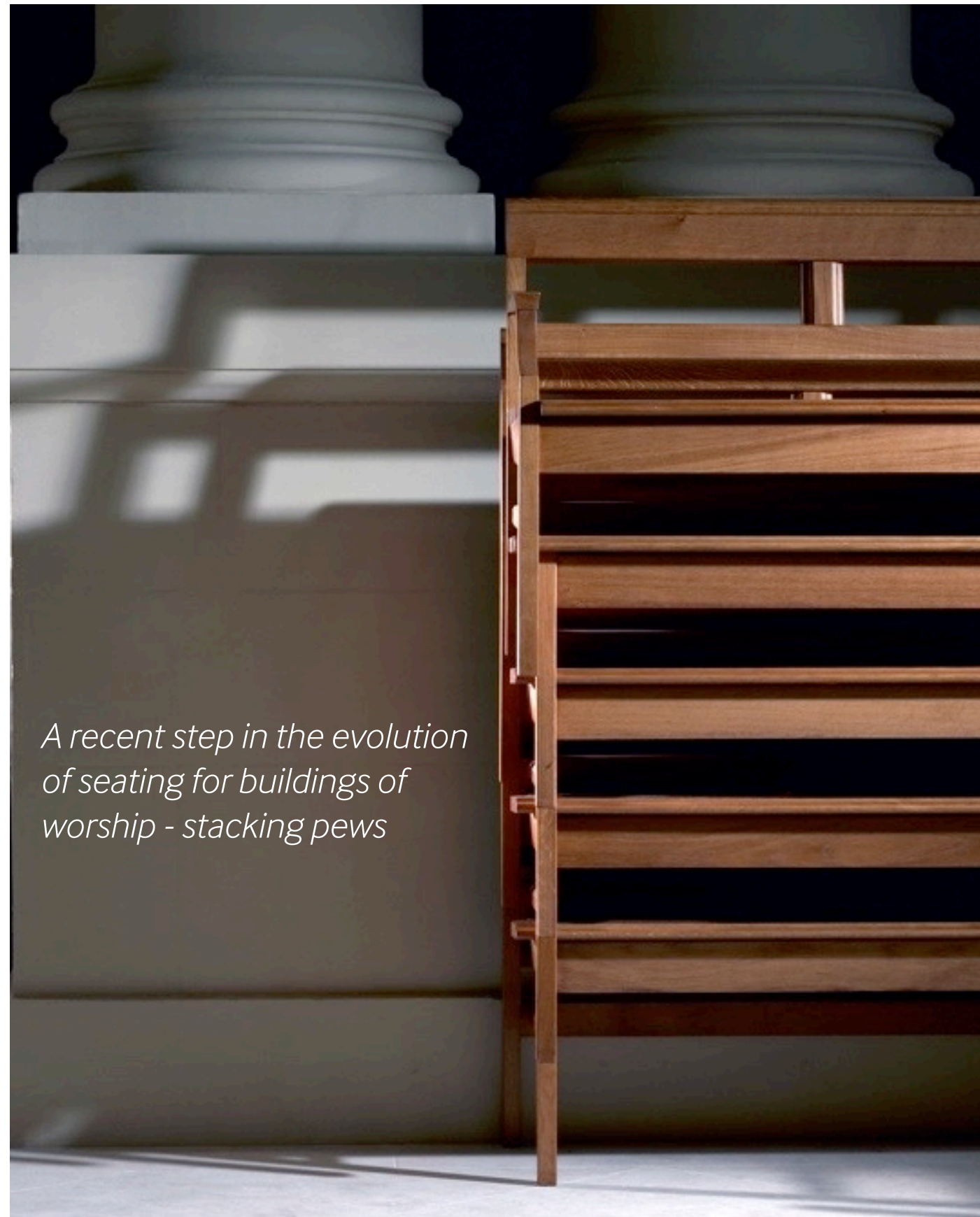

A recent step in the evolution of seating for buildings of worship - stacking pews

In 1996, after over 2000 years of evolution in church architecture, Luke Hughes designed the very first stacking pew in response to the changing needs of today's places of worship.

Early buildings of worship were left empty. Floors were often decorative and designed to be seen. Occasionally there were stone benches along the walls. Only on very special occasions were backless benches brought into play.

In the latter half of the 20th century, 're- configurability' became the desire. The use of buildings of worship for community meetings, for plays and concerts, and for different levels of worship can be better accommodated if the furniture can be moved. Chairs may have seemed the immediate solution and parish communities have rushed to strip out pews and replace them with the cheapest option - products that were principally designed for the post-war educational or health-care markets. These have generally been manufactured in light-coloured timber, pressed metal, plywood and tubular steel, or even polypropylene, some with highly coloured fabrics - hardly conducive to the interior of a fine architectural or liturgical interior.

Pews look far better than chairs in most worship interiors, whatever their age or style. They enable congregations to bunch up, are easy to move, lighter and more versatile than conventional pews and less obtrusive than chairs. It is a concept that, with changes to sizes, colours, mouldings, can accommodate a huge variety of layouts and be adapted to suit the architectural style of each building.

It is clear to us that every building of worship is unique so there is rarely such a thing as a standard solution. The examples show here illustrate how we have adapted the general concept to fit a range of outstanding architectural spaces.

So, when it comes to seating for buildings of worship, it is no longer merely a matter of buying new chairs. It is about running a major community building, albeit one steeped in history, sentiment and splendour.



© Luke Hughes Designs 2026

Charterhouse stacking pews - light enough to handle, heavy enough to be stable





The basic design (without upholstery or lower shelf) - 2, 3 and 4 seat version



Easy to stack without crushing your knuckles...



No danger of cutting into your calf muscles...



Optional back panels...



Optional arms (and alternative top rail detail) ...

Charterhouse stacking pews

© Luke Hughes Designs Ltd 2025





Charterhouse stacking pews

Sheffield Cathedral



Charterhouse stacking pews

Sheffield Cathedral





Charterhouse stacking pews (with modified top rail)

Sheffield Cathedral





Charterhouse stacking pews

Bristol Cathedral



Charterhouse stacking pews

Epsom College Chapel

10

© Luke Hughes Designs Ltd 2025



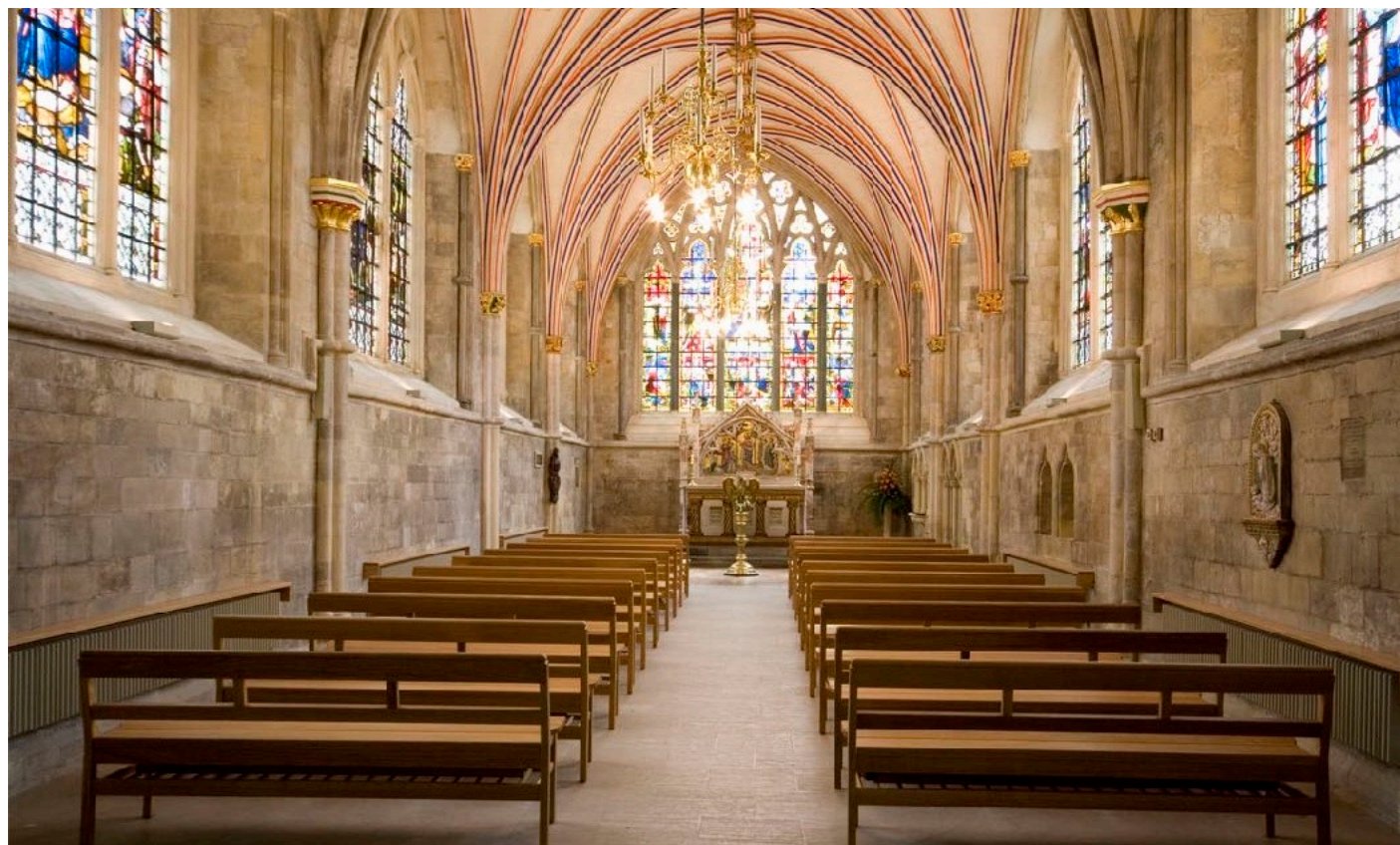

Charterhouse stacking pews

Chichester Cathedral





Charterhouse stacking pews (note: floor grid used for setting out)

St Andrew's Holborn





Charterhouse stacking pews

All Saints, Carshalton





Charterhouse stacking pews

Boxgrove Priory





Charterhouse stacking pews

St Andrew, Feniton





Charterhouse stacking pews

Bangor Cathedral, Wales





Charterhouse stacking pews

St Machar's Cathedral, Aberdeen





Charterhouse stacking pews
Highgate Cemetery

Reordering scheme

All Hallows, Gospel Oak (2016 and 2025)





Charterhouse stacking pews

All Hallows, Gospel Oak





Charterhouse stacking pews

All Hallows, Gospel Oak



Re-ordering scheme

St Thomas & St Edmund, Salisbury (2019)





Charterhouse stacking pews

St Thomas's, Salisbury





20% with arms
St Thomas & St Edmund, Salisbury



Re-ordering scheme

St Paul's, Covent Garden (2021)



© Luke Hughes Designs Ltd 2025



photo courtesy of the Rector, St Paul's Covent Garden

Charterhouse stacking pews

St Paul's, Covent Garden





photo courtesy of the Rector, St Paul's Covent Garden

Cleared for musical reception

St Paul's, Covent Garden





Arm version with panelled back



photo courtesy of the Rector, St Paul's Covent Garden

Charterhouse stacking pews (with optional back panel)

St Paul's, Covent Garden





Looking neat, even when stacked

Stacking pews arranged along wainscot

St Paul's, Covent Garden





Arm version (on right) stacks on non-arm version but not vice-versa

Charterhouse stacking pews (with optional back panel)

St Paul's, Covent Garden





Cleared for social events

St Paul's, Covent Garden



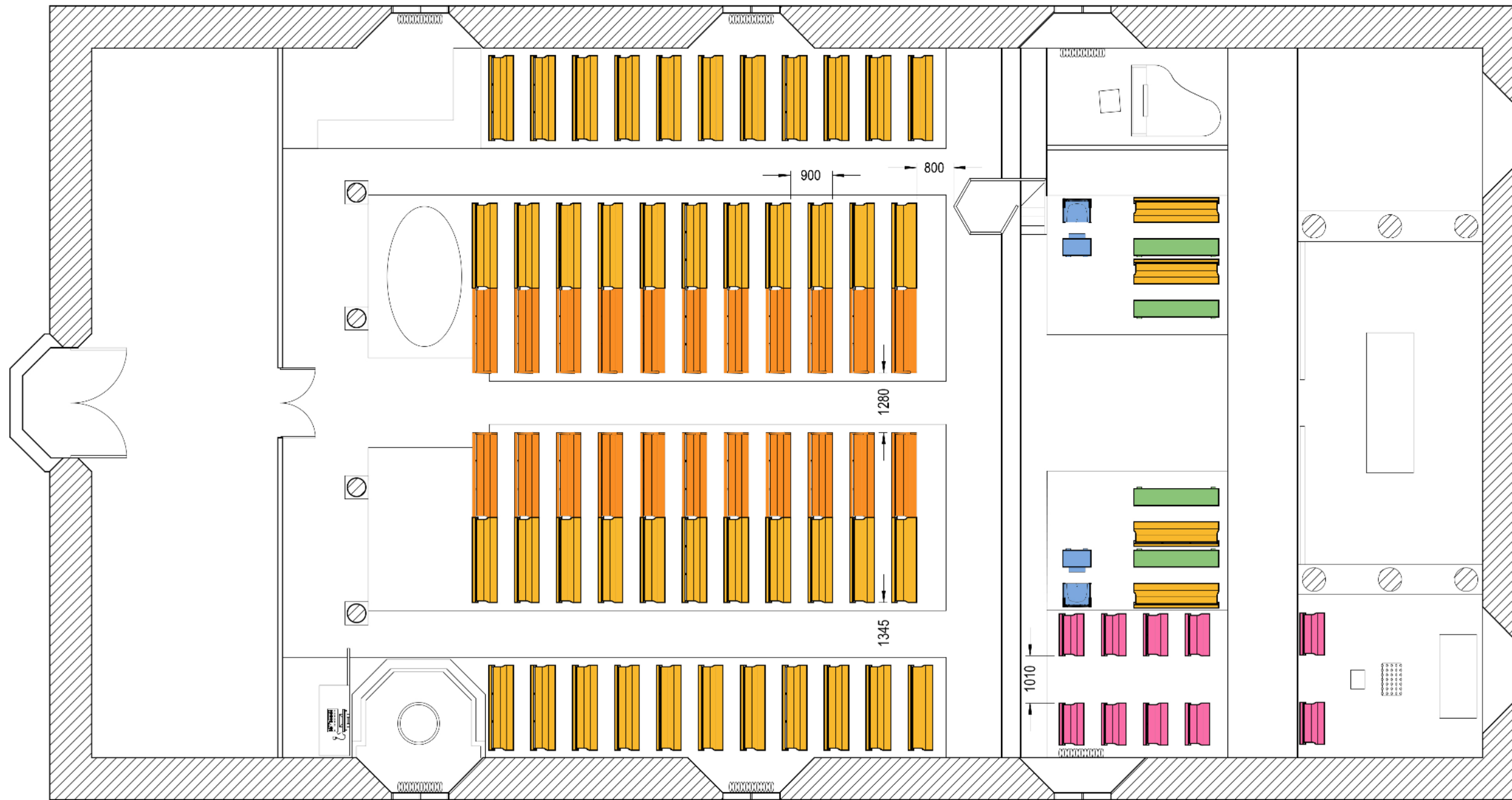

FOR INFORMATION DO NOT MANUFACTURE

Default layout

St Paul's Covent Garden



PROJECT ST PAUL'S, COVENT GARDEN
 DRAWING EXISTING LAYOUT
 STATUS For information
 DRAWING N° 20280/01/012
 MATERIAL n/a
 FINISH n/a
 QUANTITY n/a

Drawn by OO Scale 1:100 @ A3 Date 13.1.22

Dimensions in millimetres Do not scale off drawing
 Do not be disclosed to a third party without written permission
 © Luke Hughes & Company Limited 2022
 info@lukehughes.co.uk lukehughes.co.uk Luke Hughes ©
 +44 (0)20 7494 5995

Possible storage area for stacks

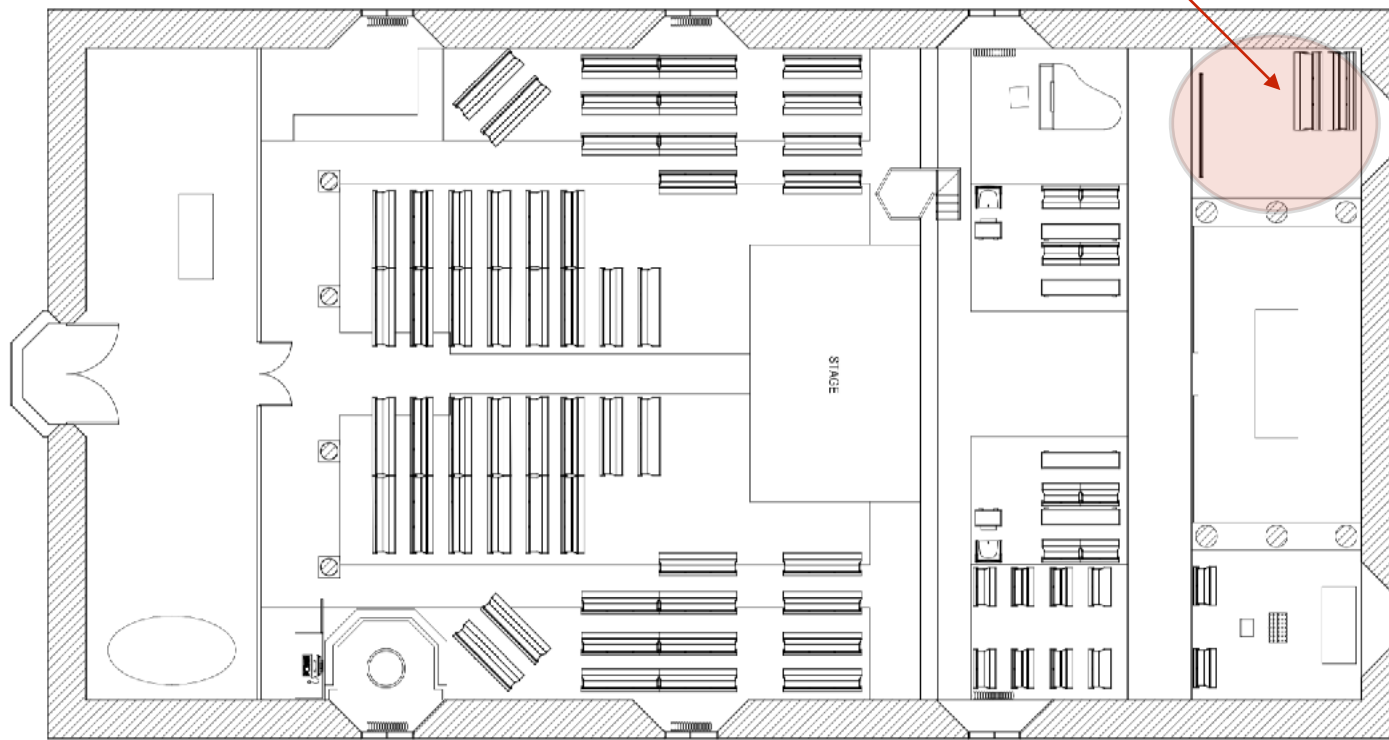

Theatre performance (e.g. during 2018, there were 80 concerts and 70 theatre performances)

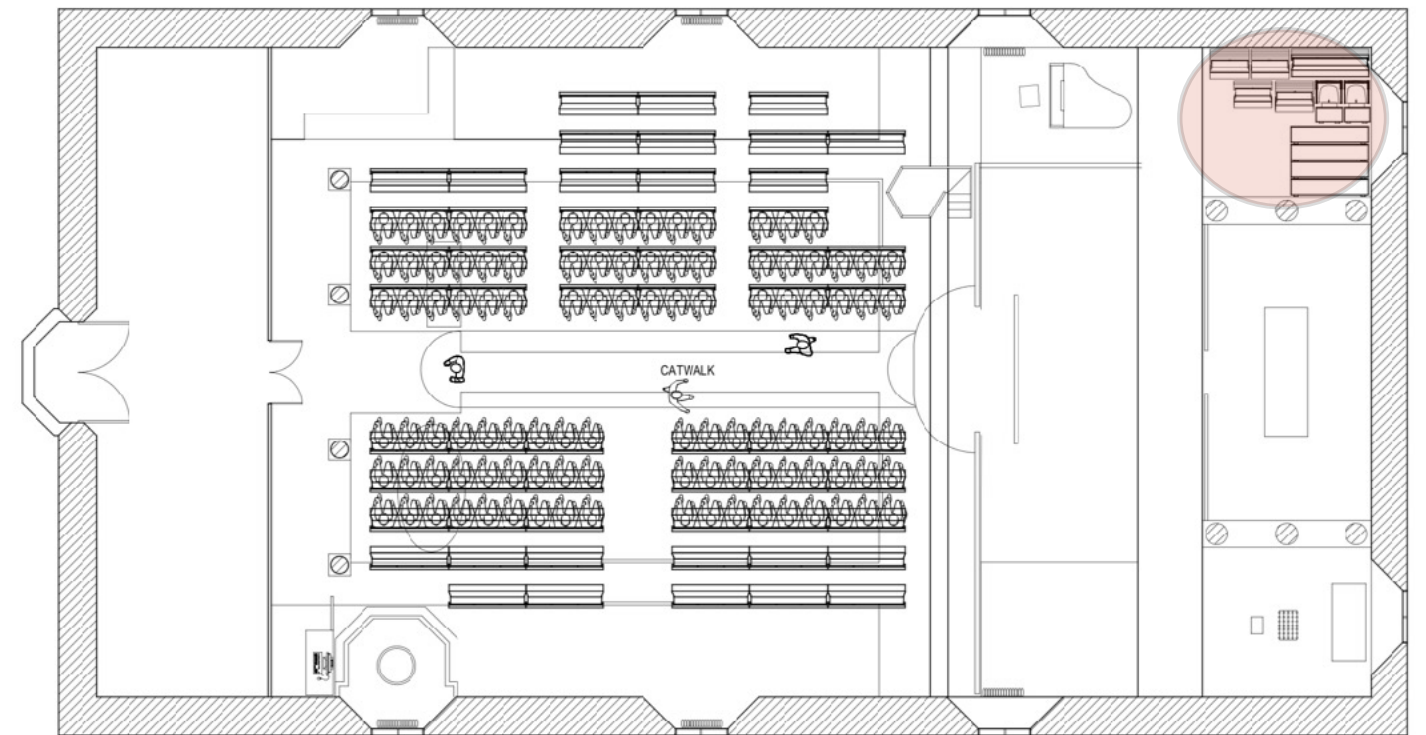

Fashion show (e.g. during London Fashion Week)

50 benches stacked behind one row, laid out for elderly or infirm - this can be split between the South and North side

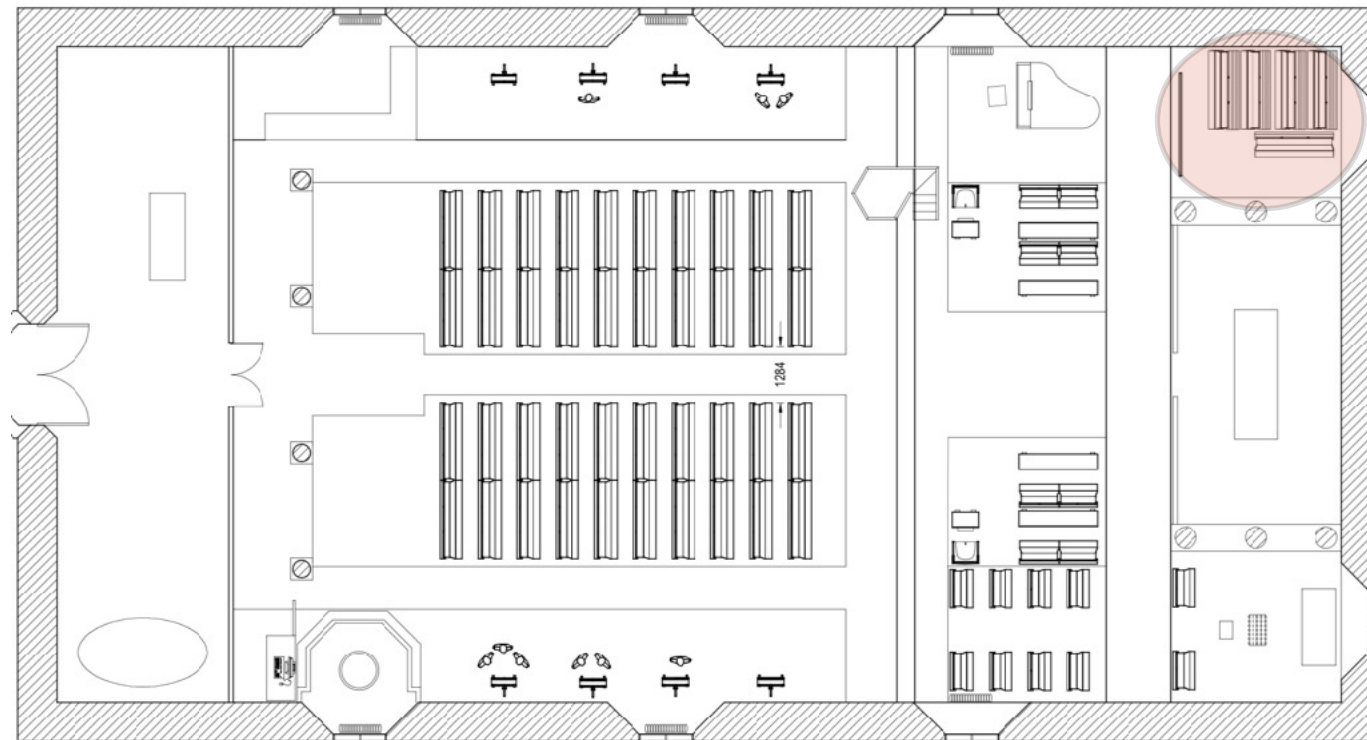

Art exhibition (e.g. the numerous requests from the Performance Galleries at the Victoria and Albert Museum)

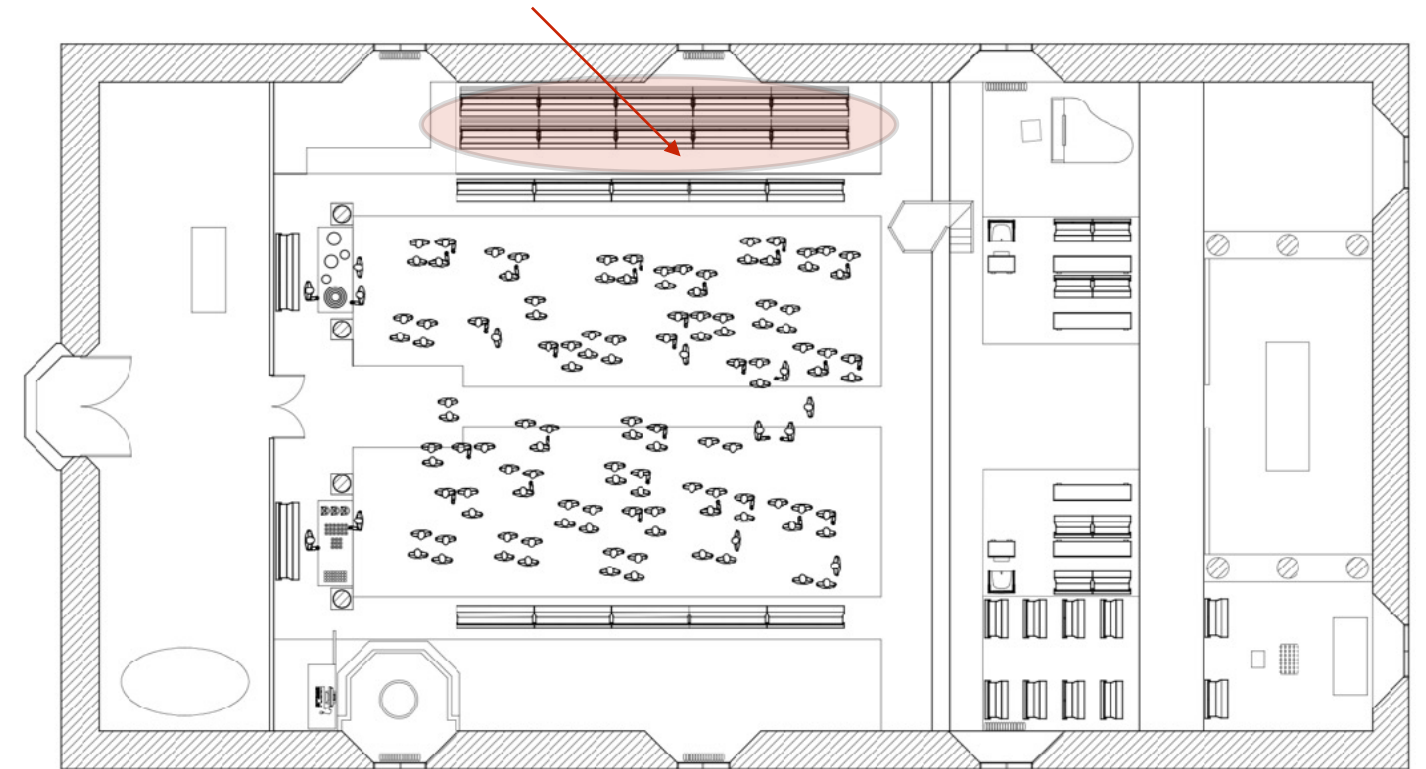

Drinks reception (e.g. AGM of Covent Garden Community Association)

Other possible layouts

St Paul's, Covent Garden



Reordering scheme (2026)

St Mary Magdalene, Richmond





Looking East
St Mary Magdalene, Richmond





Clergy seats, prayer-desk, altar etc.

St Mary Magdalene, Richmond





Nave (stacking pews)
St Mary Magdalene, Richmond

Re-ordering scheme

Cathedral of the Incarnation (Long Island, NYC)

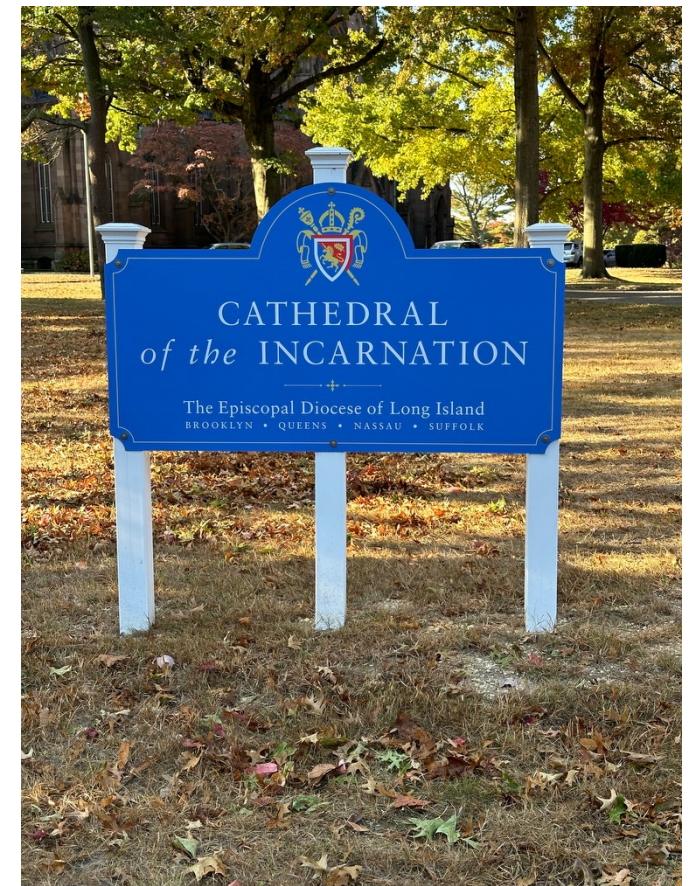

© Luke Hughes Designs Ltd 2025

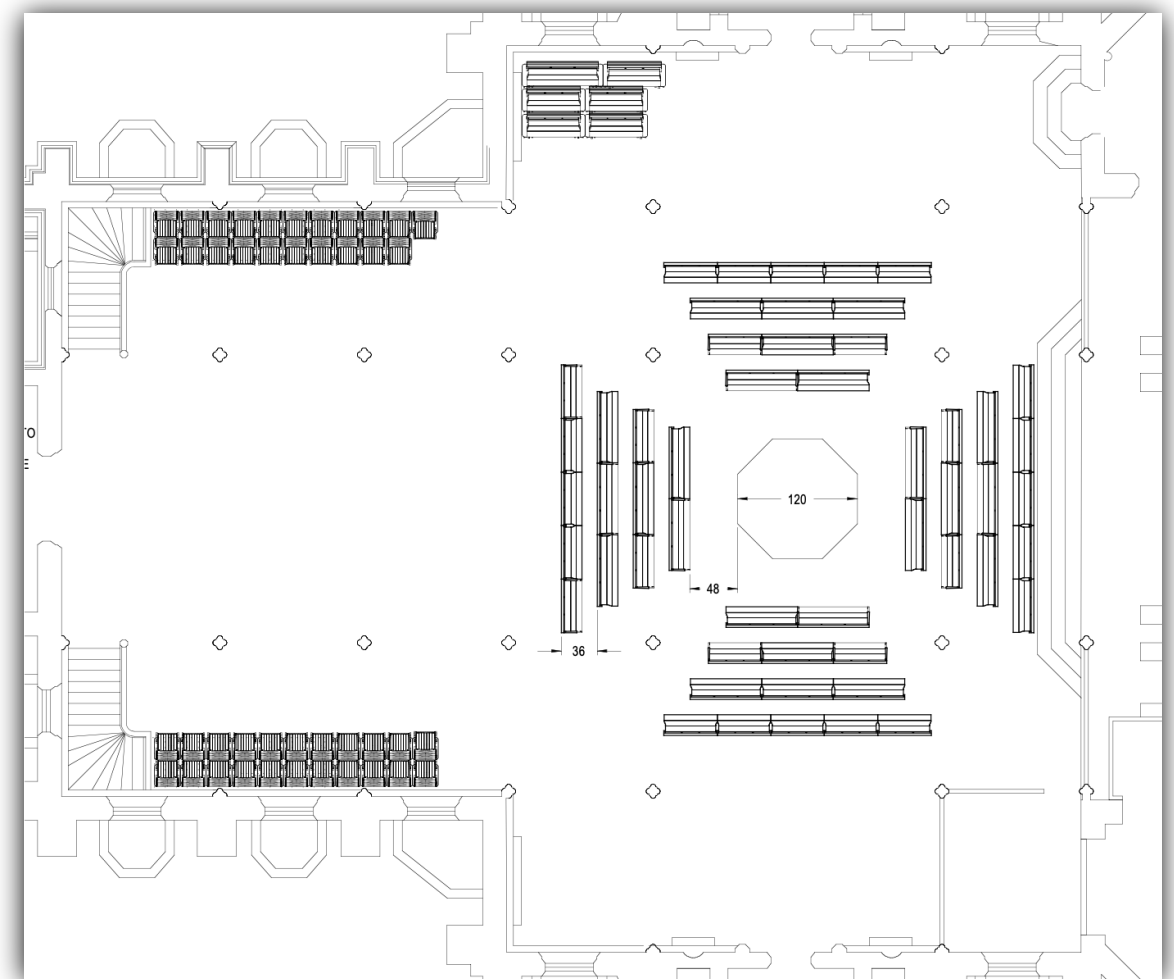
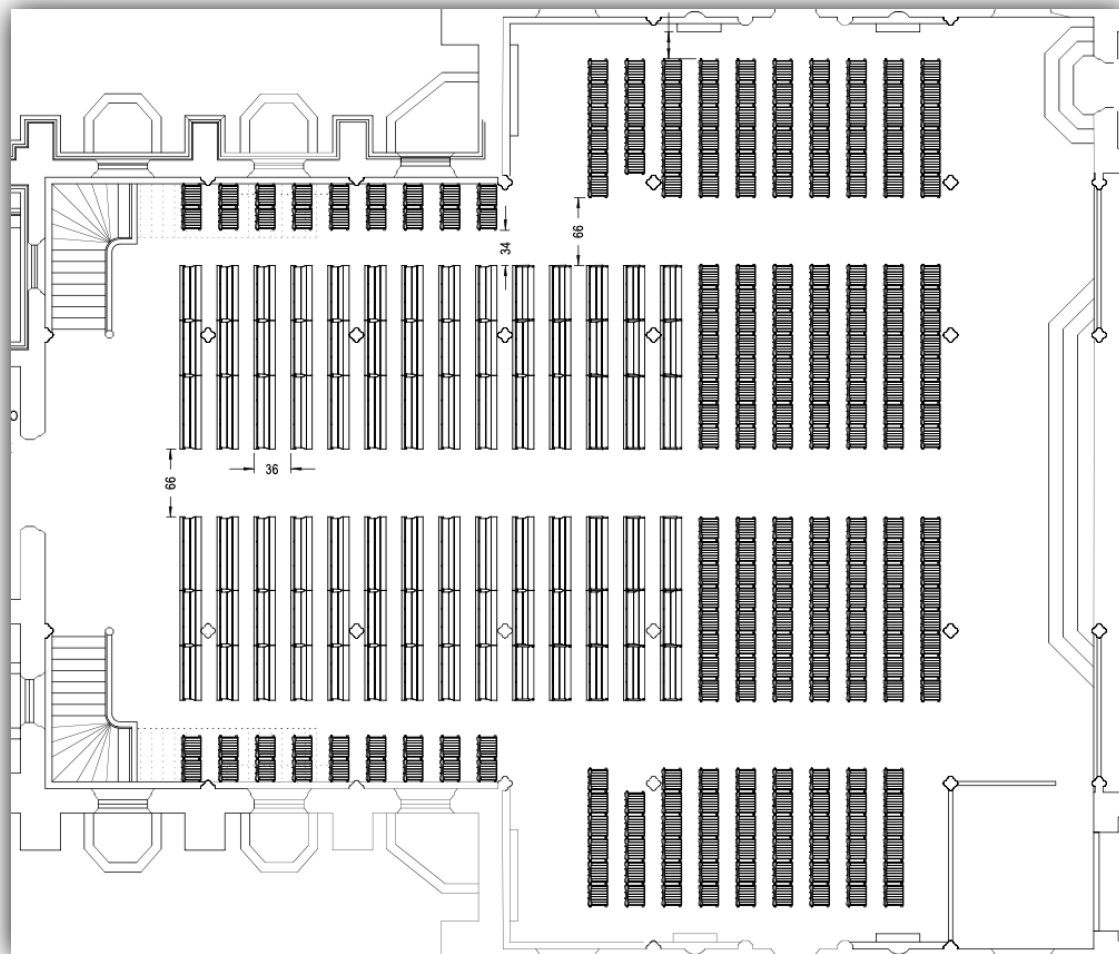
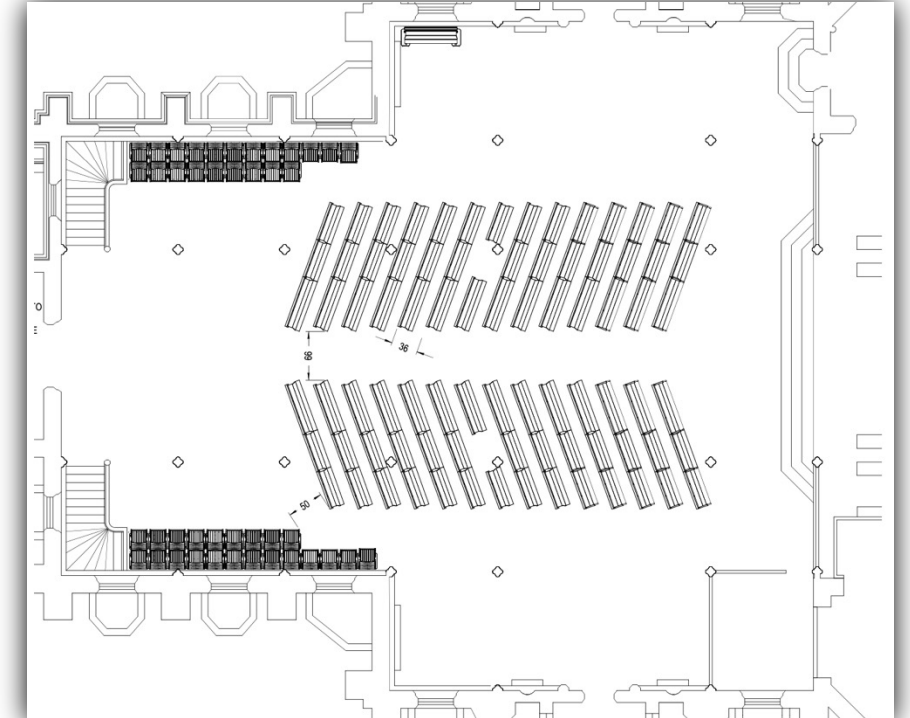
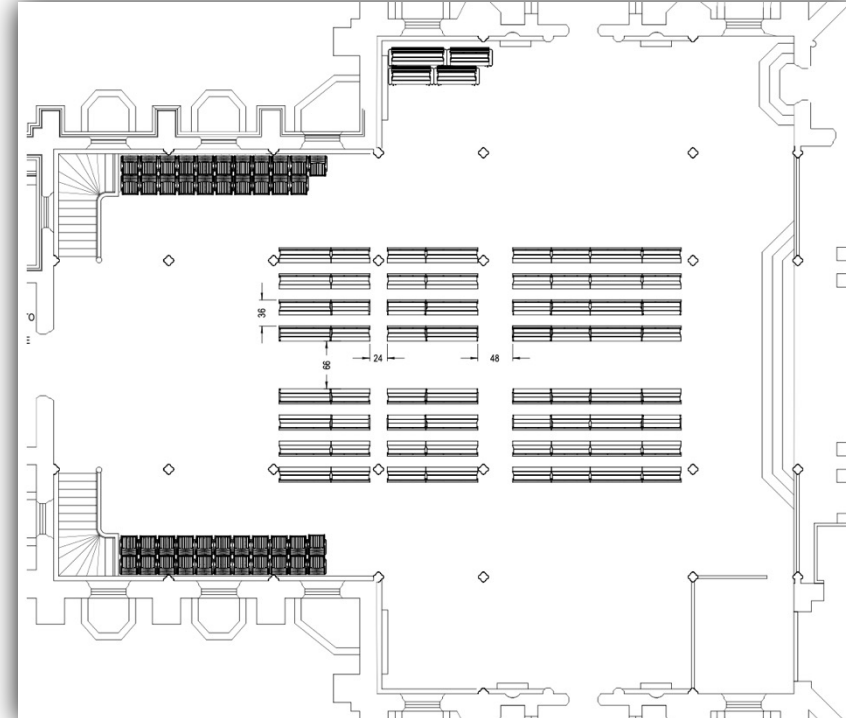
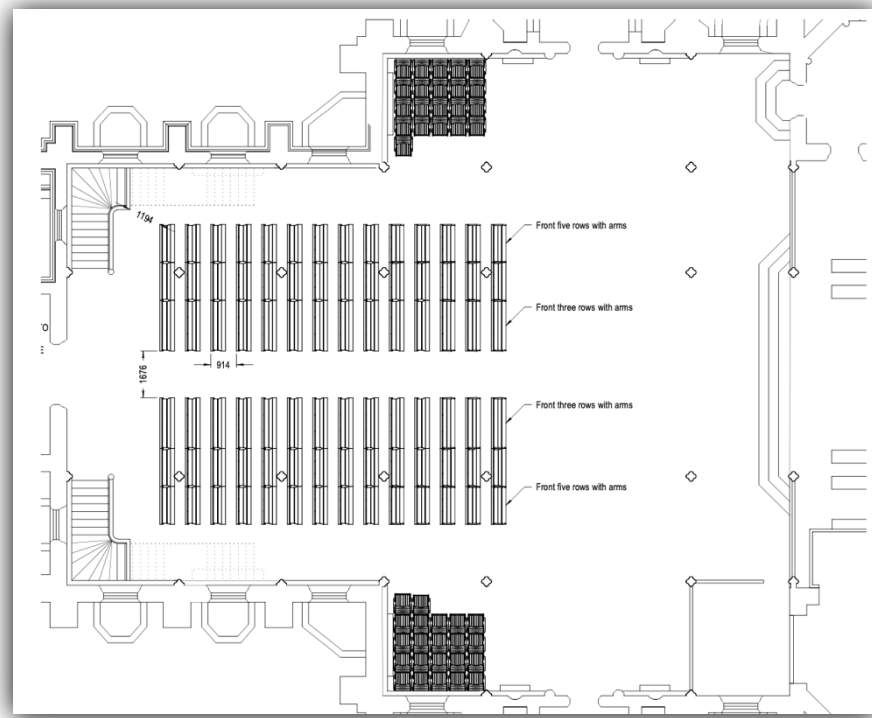

Possible layouts (using both stacking pews and chairs)

Cathedral of the Incarnation, Long Island NY





New seating (combination of *Coventry* chairs and *Charterhouse* stacking pews)

Cathedral of the Incarnation, Long Island NY

© Luke Hughes Designs Ltd 2025





photo courtesy of Kyle Sabo

Laid out in collegiate style
Cathedral of the Incarnation, Long Island NY





photo courtesy of Kyle Sabo

Social distancing during COVID

Cathedral of the Incarnation, Long Island NY





Family Eucharist
Cathedral of the Incarnation, Long Island NY





Showing loose upholstered cushions



Showing linking mechanism

Further views

Cathedral of the Incarnation, Long Island NY



Re-ordering scheme

The Shrine of Our Lady of Pompeii, Chicago (May 2026)



© Luke Hughes Designs 2026



© Luke Hughes Designs 2026

Looking East
Shrine of Our Lady of Pompeii, Chicago



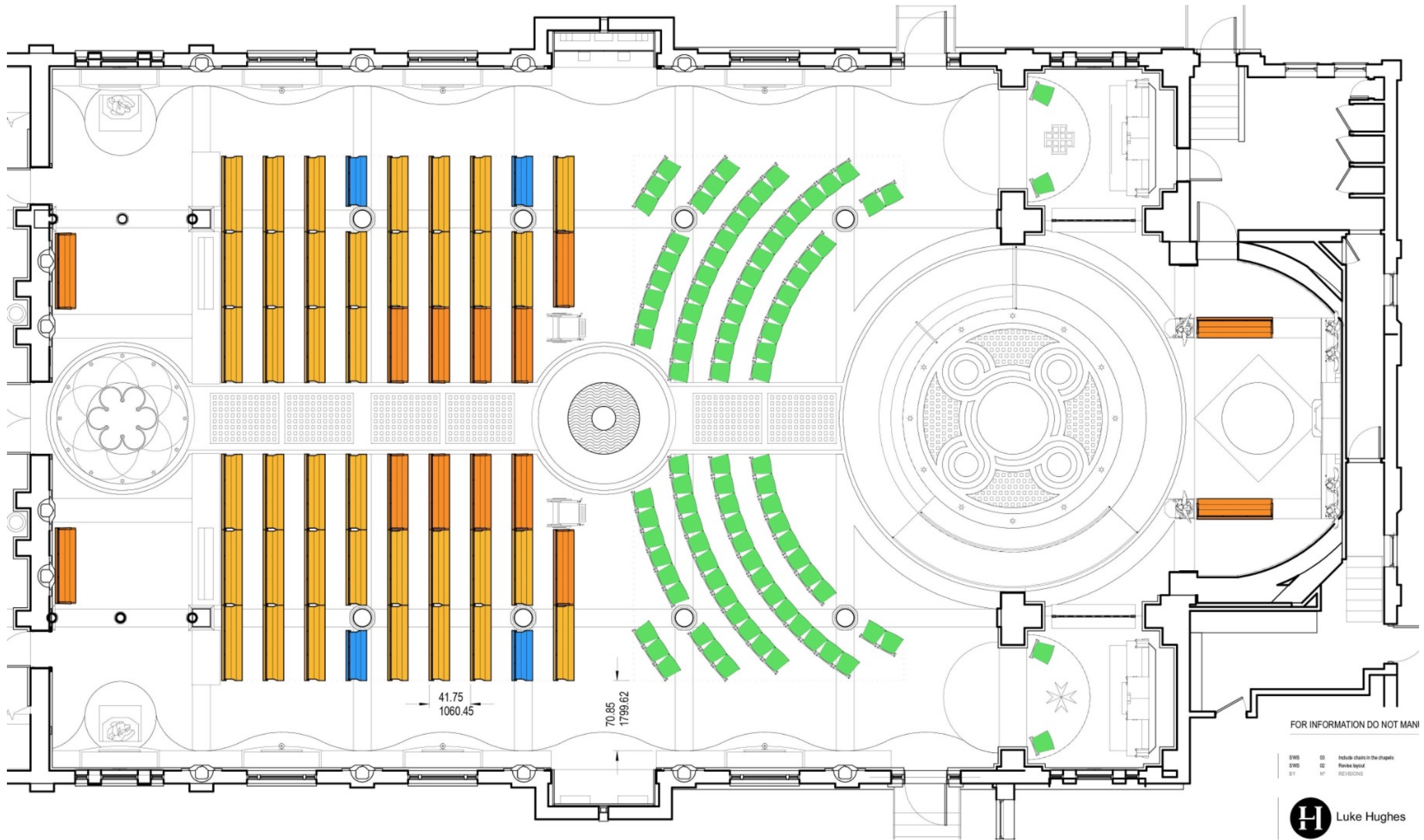

Optimum layout

Shrine of Our Lady of Pompeii, Chicago





© Luke Hughes Designs 2026

Looking West - chairs in the front rows, pews in the rear
Shrine of Our Lady of Pompeii, Chicago





© Luke Hughes Designs 2026

Looking North East - chairs and kneelers
Shrine of Our Lady of Pompeii, Chicago





© Luke Hughes Designs 2026

'St Edmund's' chairs (and kneelers)
Shrine of Our Lady of Pompeii, Chicago





Works 'before' and in progress
Shrine of Our Lady of Pompeii, Chicago



Reordering scheme

St Philip Howard, Cambridge (March 2026)



© Luke Hughes Designs 2026

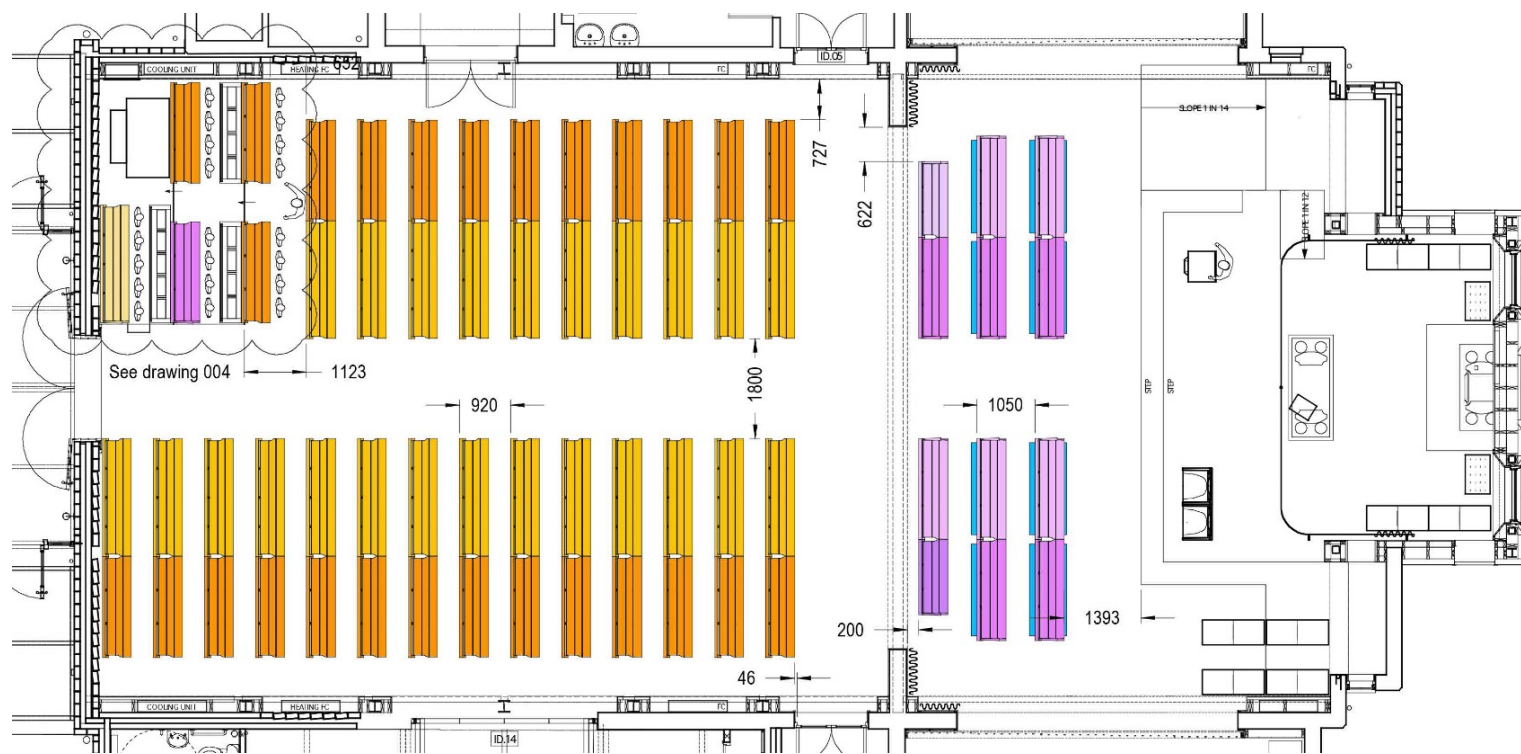

© Luke Hughes Designs 2026

Some of the final layouts
St Philip Howard, Cambridge





© Luke Hughes Designs 2026

Looking South West
St Philip Howard, Cambridge



Looking N



© Luke Hughes Designs 2026

Looking North West
St Philip Howard, Cambridge



“Unless the Lord builds a house, in vain do its builders labour” (Psalm 127:1)

CONSECRATION AND BLESSING MASS

FOR THE PARISH CHURCH OF

ST. PHILIP HOWARD

CAMBRIDGE



Celebrants

The Right Reverend **Peter Collins** - Bishop of East Anglia
(Main Celebrant & Anointing of the Altar)

The Right Reverend **Alan S. Hopes** - Bishop Emeritus of East Anglia
(Blessing & Sprinkling of Holy Water)

Mar Joseph Srampickal
Bishop of the Catholic Syro-Malabar Eparchy of Great Britain
(Anointing of the Walls of the Church)

Mar Thomas Tharayil
Archbishop of Changanassery (Kerala)
(Homily)

SUNDAY, 26TH APRIL 2026 AT 12 NOON



© Luke Hughes Designs 2026

Laid out for the dedication service, looking East
St Philip Howard, Cambridge



Reordering scheme

Congregation Beit Simchat Torah (Sept 2016)



© Luke Hughes Designs Ltd 2025



Dedication service (15 April 2016)
Congregation Beit Simchat Torah, NYC





Linking mechanism (and fixed upholstered cushion)

Congregation Beit Simchat Torah, NYC



Main prayer hall (with bespoke curved pews)

Congregation Beit Simchat Torah, NYC





Charterhouse stacking pews (handling and storage)

Sheffield Cathedral





Storage of the pews remains using the dollies - thus avoids double-handling

Charterhouse stacking pews on transport dollies

St Paul's, Covent Garden



Charterhouse stacking pew family



Charterhouse pew 2 seat
W 900mm (35 7/16")
D 521mm (20 1/2")
H 768mm (30 1/4")



Charterhouse pew 3 seat
W 1360mm (53 1/2")
D 521mm (20 1/2")
H 768mm (30 1/4")

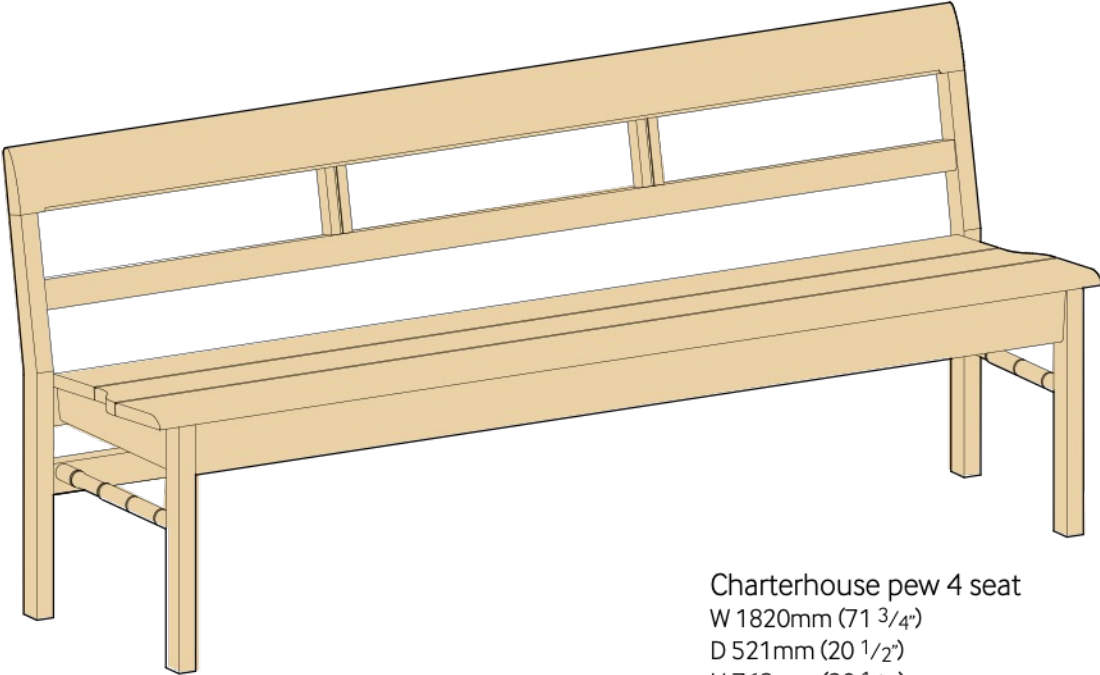
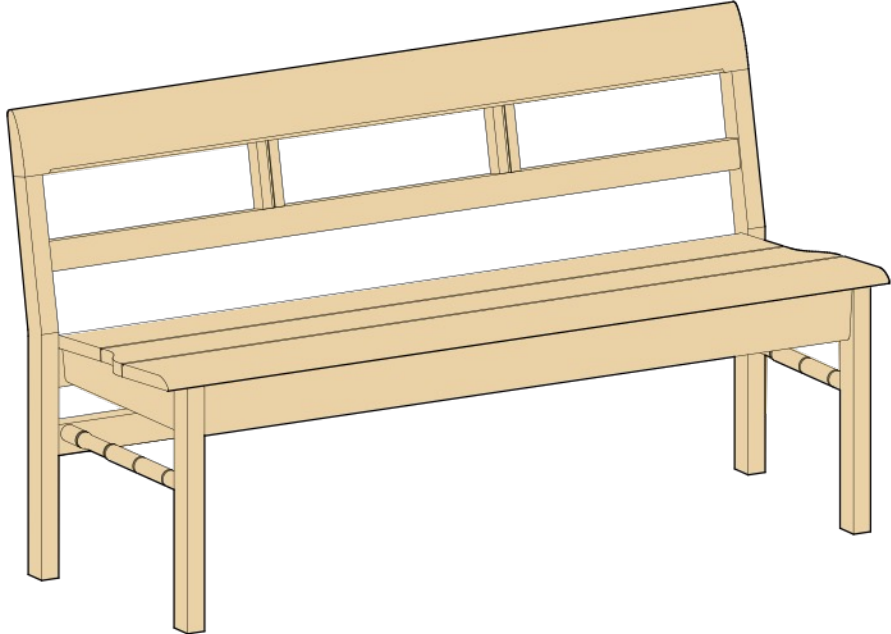

Charterhouse pew 4 seat
W 1820mm (71 3/4")
D 521mm (20 1/2")
H 768mm (30 1/4")

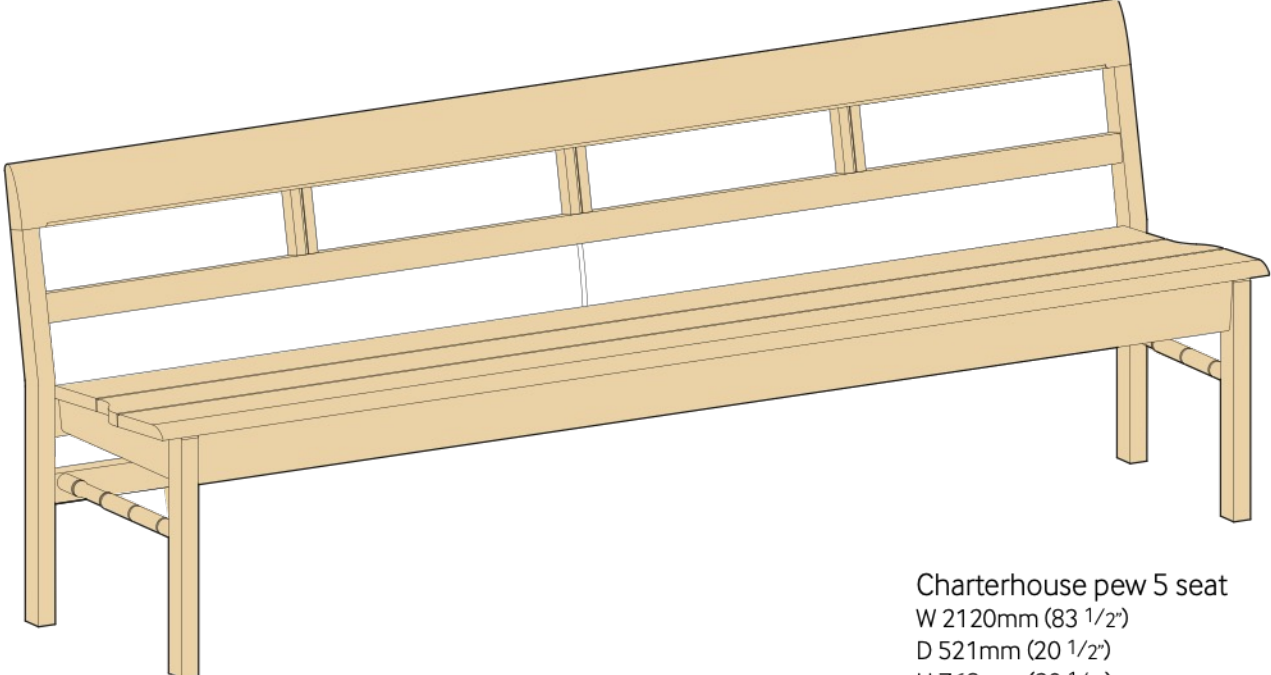

Charterhouse pew 5 seat
W 2120mm (83 1/2")
D 521mm (20 1/2")
H 768mm (30 1/4")

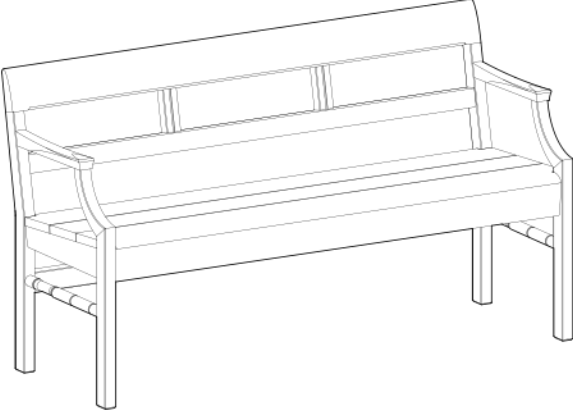
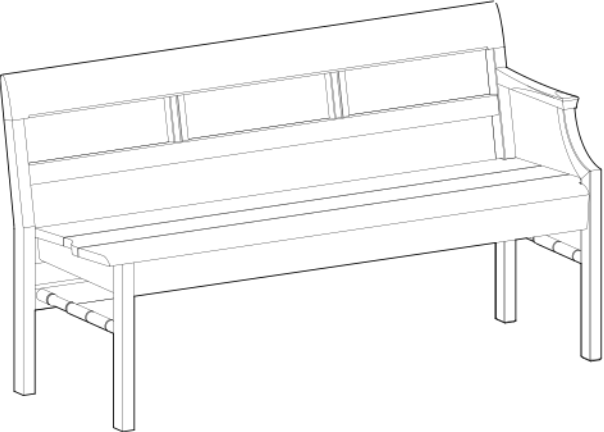
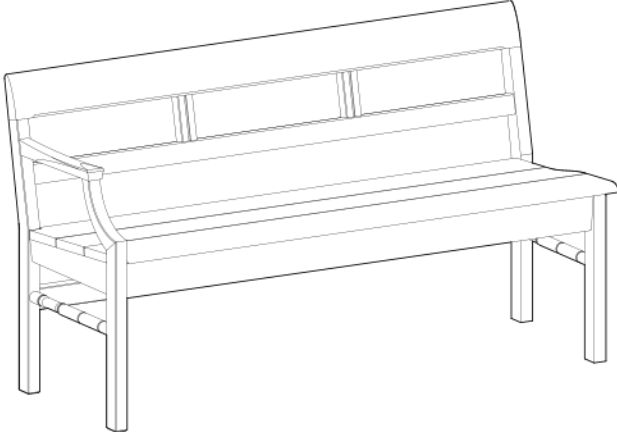

© Luke Hughes Designs 2026

Charterhouse pew dolly;

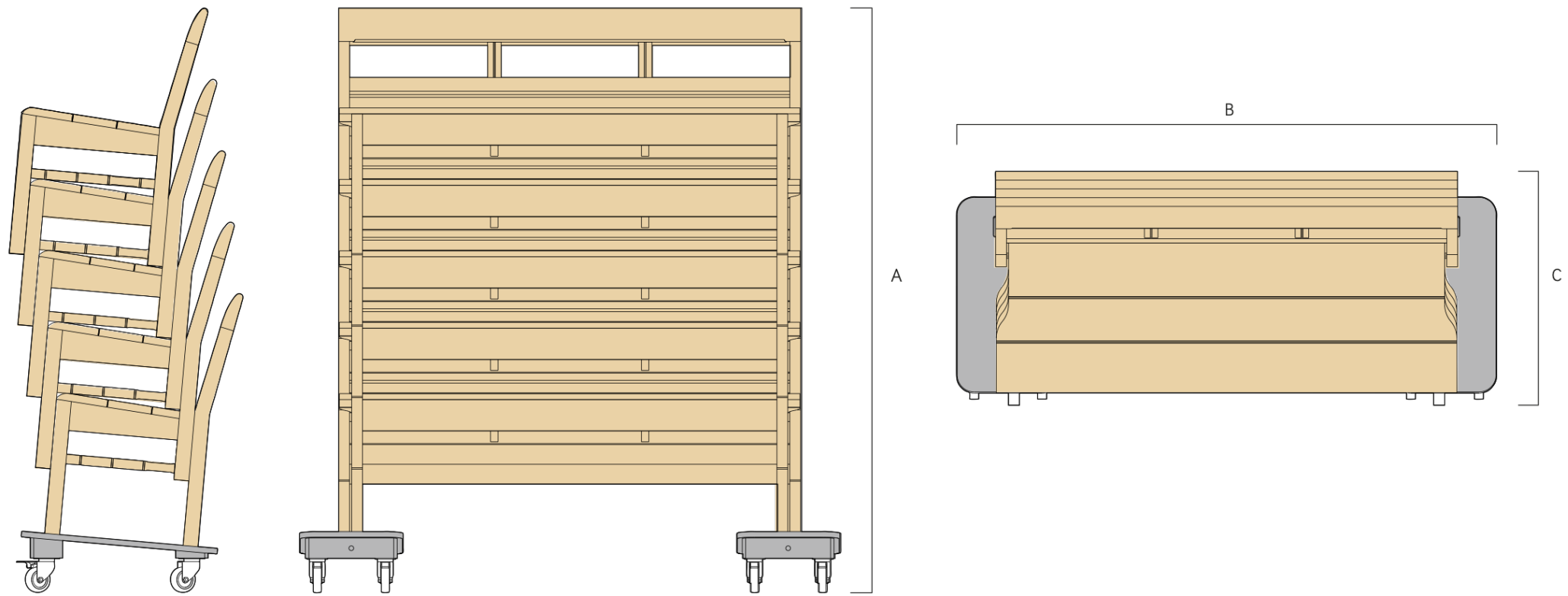

Charterhouse stacking pews on dollies

	A	B	C
2 seat pew	1721mm 68"	1128mm 44 7/16"	688mm 27 1/16"
3 seat pew	1721mm 68"	1590mm 62 5/8"	688mm 27 1/16"
4 seat pew	1721mm 68"	2058mm 81"	688mm 27 1/16"
5 seat pew	1721mm 68"	2348mm 92 7/16"	688mm 27 1/16"



St Michael & All Angels, Kingsnorth
with
Ss Peter & Paul, Shadoxhurst
Mr Norman Humphries
Churchwarden
103 Speldhurst Close
Ashford, Kent TN23 5TN
Tel: 01233 647271
E-mail: normanandruth@supanet.com



22 November 2010

Mr Luke Barton
Luke Hughes and Company
182 Drury Lane
Covent garden
London
WC2B 5PP

Dear Luke

It's been sometime now since we had our new pews, and I would like to let you know how delighted we are with them, they have made such a difference to our services, and we have three combinations of seating arrangements to date, which I have had to take photos of to remember how they go.

Apart from the church services we have held several concerts, and when we have the colour party for the children they really come into there own as the pews being stack-able and so easy to carry we can gain so much more room, even the choir can change their seating arrangements.

The other difference is we now host a number of other church meetings, at present we are hosting a ALM group which started in October and going through to January, it seems since we finished the refurbishment everyone wants to come here for their meetings, we have also had several other churches visit us to see what we have done and the comments are always the same "where did you get the pews from, and aren't they comfortable and well made" (*I did give them your address*) unfortunately most of them are unable to get rid of the pews they have as they are not in as bad a condition as ours were.

So thanks to you and your craftsmen our church is so much more versatile.

Yours sincerely

N.Humphries

Mr Norman Humphries Churchwarden Kingsnorth
on behalf of Revd. Canon Sheila McLachlan
Mrs Caryl Jones Churchwarden Kingsnorth,
Mrs Helen West Churchwarden Shadoxhurst
The PCC and congregation of St. Michael & All Angels
with St. Peter, St. Paul Shadoxhurst.



... a nave as a flexible, social space...

Buildings of Worship

Select clients

All Hallows, Gospel Oak
All Saints' Church, Carshalton
All Saints' Church, Woodford
Arundel Cathedral
Bangor Cathedral
Benenden School Chapel
Boxgrove Priory
Bristol Cathedral
Canterbury Cathedral
Cathedral of the Incarnation, NY
Cathedral of St Philip, Atlanta
Chapel of the Resurrection, Valparaiso University
Charterhouse School Chapel
Chester Cathedral
Chichester Cathedral
Church of Holy Rood, Holybourne
Church of the Holy Spirit, Southsea
Clare College Chapel
Community Synagogue of Rye, NY
Congregation Beit Simchat Torah Synagogue, NYC
Congregation Habonim, NYC
Corpus Christi Jesuit Community, Christchurch
Dorchester Abbey
Durham Cathedral
Ely Cathedral
Epsom College Chapel
Exeter Cathedral
Farm Street Church
Hereford Cathedral
Highgate Cemetery
Holy Trinity, Cuckfield

Holy Trinity, Geneva
Hull Minster
Hurst Pierpoint College Chapel
Keble College Chapel
Lichfield Cathedral
Lincoln's Inn Chapel
Mucknell Abbey
New North London Synagogue
Our Lady of Pompeii, Chicago IL
Park Avenue Synagogue, NYC
Peterborough Cathedral
Portsmouth Cathedral
Rochester Cathedral
Salisbury Cathedral
Sheffield Cathedral
Shrewsbury Abbey
Shrewsbury School Chapel
Sidney Sussex College Chapel
Southwark Cathedral
St Alban's Church, Romford
St Andrew's, Holborn
St Andrew's, Alderton
St Andrew's, Feniton
St Andrew's, Southwark
St Andrew's, Stapleford
St Andrew's, Surbiton
St Augustine's, Rumney
St Barnabas, Dulwich
St Bartholomew's, Wilmslow
St Catherine's, Burbage
St Clement Dane's
St Dunstan's Episcopal Church, Madison WI
St Dunstan's Church, Mayfield

St Edmundsbury Cathedral
St Francis at the Engine Room
St George's Chapel, Windsor
St George's, Bloomsbury
St George's, Bristol
St George's, Oakdale
St Giles' Cathedral, Edinburgh
St Joan of Arc, Highbury
St John the Baptist, Tisbury
St John's Presbyterian Church, San Francisco, CA
St John's, Waterloo
St John's, Berwick St John
St John's, Blackheath
St John's, Notting Hill
St John's, Preston
St John's, Shirley
St John's, Tisbury
St John's Chapel, Tower of London
St Joseph's Hospice, Hackney
St Lawrence Jewry
St Luke's, Darien, CT
St Luke's, Chelsea
St Machar's Cathedral, Aberdeen
St Margaret Pattens
St Margaret's, Bethersden
St Mark's, Swindon
St Martin's, Barford St Martin
St Mary and St Giles, Stony Stratford
St Mary Magdalene, Newark
St Mary Magdalene, Richmond
St Mary the Less, Durham
St Mary the Virgin, Oxford
St Mary-at-Hill, Billingsgate

St Mary-le-Bow, Cheapside
St Mary's, Witney
St Mary's House, Brighton
St Mary's, Ealing
St Mary's, Easton
St Mary's, Fairford
St Mary's, Houghton-on-the-Hill
St Mary's, Iffley
St Mary's, Kempford
St Mary's, March
St Mary's, Shroton
St Mary's, Somers Town
St Mary's, Twickenham
St Mary's, Witney
St Mary's, Woodbridge
St Marylebone, Marylebone
St Matthew's, Wilton, CT
St Michael and All Angels, Kingsnorth
St Michael's, Stourport
St Paul's, Covent Garden
St Paul's Cathedral
St Paul's, Croxton
St Peter Ad Vincula, Tower of London
Temple Israel, NYC
The Royal Military Guards Chapel
The Temple Church
Trinity Wall Street, NYC
Westbourne Grove Methodist Church
Westminster Abbey
Westminster Cathedral
Westminster Synagogue
Winchester Cathedral
Winchester University Chapel
York Minster



'I am writing to say ... how delighted we are with the final design and especially the proportions and detailing and how marvellous is the craftsmanship of its execution. It is a fine tribute to your design skills and determination to get things exactly right and to the skill and perfectionism of the craftsmen who made it so beautifully. I would be grateful if you could pass on our thanks

Benefactors of St Barnabas, Dulwich

'The benches achieve a spectacular understatement and show us a different building'

Vicar, St Michael's, Stourport

What can we say?! HUGE gratitude to you and all your amazing colleagues; the new seating is truly wonderful and has transformed the nave. So - thankyou to everyone who has brought this great scheme to fruition - from us all here'

Canon Philip Banks, Precentor, St Edmundsbury Cathedral

'Thanks to you and the whole team for a superb job. It has been a real pleasure doing business with you and... we are delighted with the result'

Project Manager, St Mary's, Ealing

'I especially admire your recent work - each piece is so elegant, practical and singing in harmony with the architecture around it'

Surveyor, Salisbury Cathedral

Member of the congregation were full of delight. I myself was thrilled by the quality of your craftsmanship

Canon Precentor, Rochester Cathedral

Some of the things clients say



'We are in this for permanence, for eternity, so our furnishings, while being flexible, have to signal something of that as well... Luke Hughes's designs provide that noble look and effect of permanence'

Bishop of London, June 2012

Luke Hughes
Aldwych House
71-91 Aldwych
London WC2B 4HN
United Kingdom

Luke Hughes
Aldwych House
71-91 Aldwych
London WC2B 4HN
United Kingdom

T +44 20 7404 5995
info@lukehughes.co.uk
lukehughes.co.uk

Established in Covent
Garden since 1981

Copyright © 2025 Luke Hughes Designs

For further technical information about the chairs, linking mechanisms, storage and handling techniques, timber options etc. please contact the Design Studio.

CAD blocks are available on request.

